

LEXUS LS



 LEXUS

View
Offers



Watch
the Advert



Find
a Dealer



Book
a Test Drive



LEXUS

LS / AMAZING IN MOTION / 02

AMAZING IN MOTION

To make amazing in motion happen, you have to do things the hard way. When we developed our first car in the late Eighties, we tasked 60 designers and 1,400 engineers to create the world's most refined saloon. The result, the LS 400, changed the UK automotive landscape and gave luxury driving a new name.

The LS is no less extraordinary. Built at the most award-winning plant on Earth, and fitted with an ultra-smooth V8 petrol engine or V8 Lexus Hybrid Drive, a remarkable 3,000 improvements have been made.

Incredibly comfortable and enjoyable to drive - and also available as an F SPORT model - it's the most refined Lexus saloon ever built.

THE MOST REFINED
LEXUS SALOON
EVER BUILT



View Offers



Watch the Advert



Find a Dealer



Book a Test Drive



LEXUS



ENJOY AN AMAZINGLY QUIET LUXURY SALOON

The LS is an incredibly quiet car in which to travel. By perfecting a breakthrough laser screw welding process to make the chassis even stiffer, we significantly reduced vibrations. Wind noise has been lessened thanks to a near-flat underbody and tiny winglets fitted to the front door frame mouldings and rear lights. Finally, if desired, the driver can select COMFORT mode which adjusts the air suspension for a smoother and more relaxed ride.

SUPREMEY TRANQUIL

View Offers



Watch the Advert



Find a Dealer



Book a Test Drive



LEXUS



WARM WELCOME

The LS is equipped with advanced technology to provide an 'Omotenashi' welcome - the Japanese spirit of hospitality. As you approach with the electronic smart key, guiding lights on the wing mirrors and the LED clock are activated automatically. Once seated, press the Start button and a beautiful animation commences on the central display, while champagne-coloured LED light flows gently along the dashboard. Inside, on selected models you can enjoy a reclining Shiatsu massage seat, relax with 19-speaker Mark Levinson® audio, or watch a DVD or Blu-ray® disc on a 9-inch monitor.

CHAMPAGNE
COLOURED LEDS
ILLUMINATE
THE DASHBOARD

View Offers



Watch the Advert



Find a Dealer



Book a Test Drive



THE ICONIC LEXUS GRILLE SITS BETWEEN LED HEADLIGHTS

The bold design of the LS features the iconic Lexus 'spindle grille' set between elegant, advanced LED headlights. Sleek new daytime running lights and fog lights frame the Lexus 'L' emblem. The LS 600h is the first Lexus model to introduce LEDs for all exterior lights, giving the car a distinctive appearance on the road.

ICONIC DESIGN



LS 600h

View Offers



Watch the Advert



Find a Dealer



Book a Test Drive



LEXUS

GRADES / LS 600h / 10

LS 600h: THE POWER OF h

The LS 600h delivers breathtaking performance, yet is amazingly efficient for its size. Comprising a 5.0-litre V8 petrol engine and a 224 DIN hp electric motor, this latest Lexus Hybrid Drive delivers 445 DIN hp of refined power using permanent All-Wheel Drive. Behind the wheel you'll enjoy rapid acceleration, with CO₂ emissions from only 199g/km. Or switch to Electric Vehicle mode for a near-silent drive and zero emissions.

A NEAR-SILENT
DRIVE WITH
ZERO EMISSIONS





HOW DOES LEXUS HYBRID DRIVE WORK?

1 / Starting up, driving off When starting off, the powerful electric motor can propel the LS 600h up to 41mph with electric power supplied by the hybrid battery. At this point the vehicle is almost silent, uses no petrol and produces zero emissions.

2 / Normal driving conditions At speeds above 41mph the ultra-smooth V8 direct-injection Atkinson Cycle petrol engine cuts in, almost silently, but still receives assistance from the electric motor when required.

3 / Full throttle acceleration Accelerate forcefully and the 224 DIN hp electric motor instantaneously supplements the 5.0-litre 394 DIN hp V8 petrol engine. Together they deliver a surge of torque for fast linear acceleration precisely when you need it.

4 / Deceleration, stopping, braking When decelerating or coming to a halt, the petrol engine turns off, cutting emissions to zero. Brake, or take your foot off the accelerator, and regenerative braking harnesses the kinetic energy lost in other cars. It converts this into electrical energy for storage in the hybrid battery, which is one reason why you never need to recharge a Lexus Full Hybrid.



NEW STANDARDS FOR CULTIVATED PERFORMANCE

The LS 460 luxury saloon is an amazingly refined car to drive. Powered by an ultra-smooth 4.6-litre V8 petrol engine with an 8-speed automatic transmission, it sets new standards for cultivated performance. Delivering smooth power and economy, the LS 460's engine has D-4S direct fuel injection and VVT-iE electric variable valve timing.

LS 460: PERFECTLY SMOOTH



DRIVE YOUR LEXUS YOUR WAY

Drive Mode Select allows you to choose between modes, to maximise either the car's efficiency or dynamic abilities.

1 / ECO / EV Mode In ECO mode, engine output, gear selection, air conditioning and heated seats are controlled to reduce fuel consumption. Select EV (Electric Vehicle) mode, and the LS 600h Full Hybrid provides a near-silent drive, using no petrol and emitting zero CO₂ or NO_x. In EV, ECO and NORMAL modes the instruments take on a tranquil blue colour, and the ecometer encourages you to drive more efficiently.

2 / SPORT Mode If you're in a dynamic mood, select SPORT mode and the LS immediately retunes the throttle for more responsive acceleration. Switching to SPORT mode illuminates the instruments in a vibrant red.

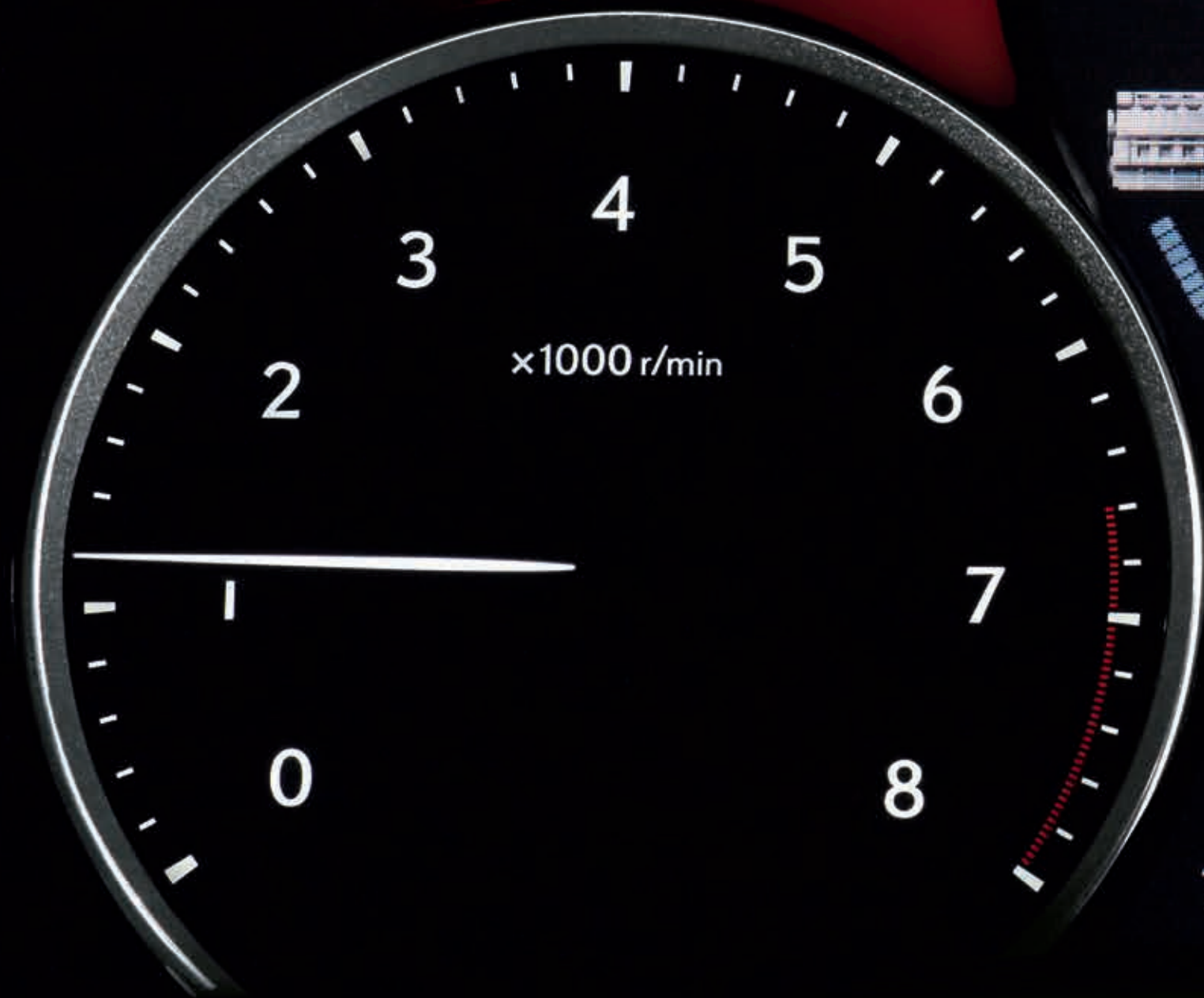
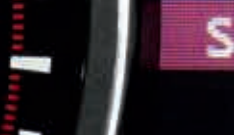
CRUISING RANG
320

View Offers



Watch the Advert



Find a Dealer



Book a Test Drive



LEXUS

GRADES / F SPORT / 18

DYNAMIC F SPORT

The LS 460 F SPORT is dynamic and exhilarating to drive, with assertive front-end styling, mesh intake grilles and 19-inch forged aluminium wheels. The car has been lowered by ten millimetres, while large Brembo® ventilated disc brakes increase driving enjoyment. Inside you'll find sumptuous sports seats with embossed F SPORT logos, aluminium pedals, metallic inlays and a steering wheel and gearshift finished in perforated leather.

RESPONSIVE AND EXHILARATING TO DRIVE





EXQUISITE CRAFTING

The LS is a wonderful car in which to travel, relax or work: the sumptuous leather driver's seat has 16-way electric adjustments and upholstery that is now 15% thicker. A new ergonomic pelvic function delivers exceptional comfort. All quality is overseen by 'Takumi' master craftspeople: witness the beautiful stitching detail on the leather dashboard and precision-machined aluminium audio controls. For the ultimate in refinement, a new striped veneer 'Shimamoku' wood and leather steering wheel is also available.

QUALITY IS OVERSEEN
BY TAKUMI MASTER
CRAFTSPEOPLE

View Offers



Watch the Advert



Find a Dealer



Book a Test Drive



PEERLESS LUXURY

Multi-adjustable rear seats with lumbar massage function and butterfly headrests are standard in the LS 600h, as are a 19-speaker Mark Levinson® Reference Surround system with Blu-ray® player and 9-inch VGA monitor. 'Climate Concierge' is a Lexus world first innovation. Constantly monitoring temperatures inside and outside the car, this integrated system automatically adjusts cabin, seat and steering wheel temperatures. Infrared sensors on the LS 600h track the body temperature of rear seat passengers, adjusting air conditioning and seat heating/cooling in their zone accordingly. Award-winning Lexus nanoe® technology releases microscopic, negatively charged ions to freshen cabin air and even moisturise your hair and skin.

CABIN AIR
MOISTURISES
YOUR HAIR AND SKIN





REFINED DESIGN

THE DISPLAY CAN BE OPERATED BY VOICE

The driver's seat in the LS is an amazing place to be. Your first points of contact are the beautifully crafted leather and wood steering wheel and gearshift that is finished in aluminium. Perfectly positioned for a relaxing drive, the stunning 12.3-inch central display can be operated by voice command or Remote Touch. Its split-screen capability allows you to simultaneously access information, such as Audio/Climate Control/Lexus Premium Navigation. Other innovations include the dynamic LED interior illumination system, and an analogue clock with GPS function that cleverly adjusts itself to the local time zone.

ADVANCED SAFETY

On the LS 600h, our Advanced Pre-Crash Safety can even detect errant pedestrians. Driver Monitoring will warn you if you are becoming tired, while Lane Keeping Assist stops you drifting out of lane. Blind Spot Monitor uses radar to warn you of unnoticed vehicles when changing lanes, and Rear Pre-Crash activates headrests to reduce whiplash in a back end collision. For safer driving in the dark, an optional feature on the LS 600h is the Lexus Night View, which displays infrared images of the road ahead on the 12.3-inch screen. Finally, Adaptive High Beam System (AHS) - a Lexus first - activates shutters within the headlights to partially shield illumination that may dazzle oncoming drivers.

THE LS WILL **WARN**
YOU IF YOU ARE
BECOMING TIRED



View Offers



Watch the Advert



Find a Dealer



Book a Test Drive



IMMACULATE FINISH

The LS gleams like no other luxury saloon, whatever the weather. After priming the body, and sealing it with an anti-corrosion and sound-insulation layer, we apply two special base coats. The first contains large aluminium flakes, which sparkle better under sunlight. The second includes smaller flakes, which shimmer brighter under cloudy skies. Before the final two topcoats are added, each car is wet-sanded by hand to remove any blemishes (a time-consuming process normally reserved for coach-built cars) and checked by a Takumi master craftsman as well as digitally to ensure an immaculate finish. Finally a 'self-repairing' coating is applied to protect the paintwork from light, acid rain and light surface scratching. The end result is stunning paintwork.

EACH CAR IS
WET-SANDED
BY HAND



View Offers



Watch the Advert



Find a Dealer



Book a Test Drive



LEXUS



CLEAN CONSCIENCE

Everything about the LS range is designed to minimise environmental impact. At the end of its life, up to 85% of the car can be recycled, including the LS 600h's hybrid battery. Production at Lexus' Tahara plant uses our world-famous lean manufacturing techniques, with waste kept to an absolute minimum, and the plant's Aqua Control Centre purifies thousands of tonnes of water a day.

UP TO 85%
OF THE CAR CAN
BE RECYCLED

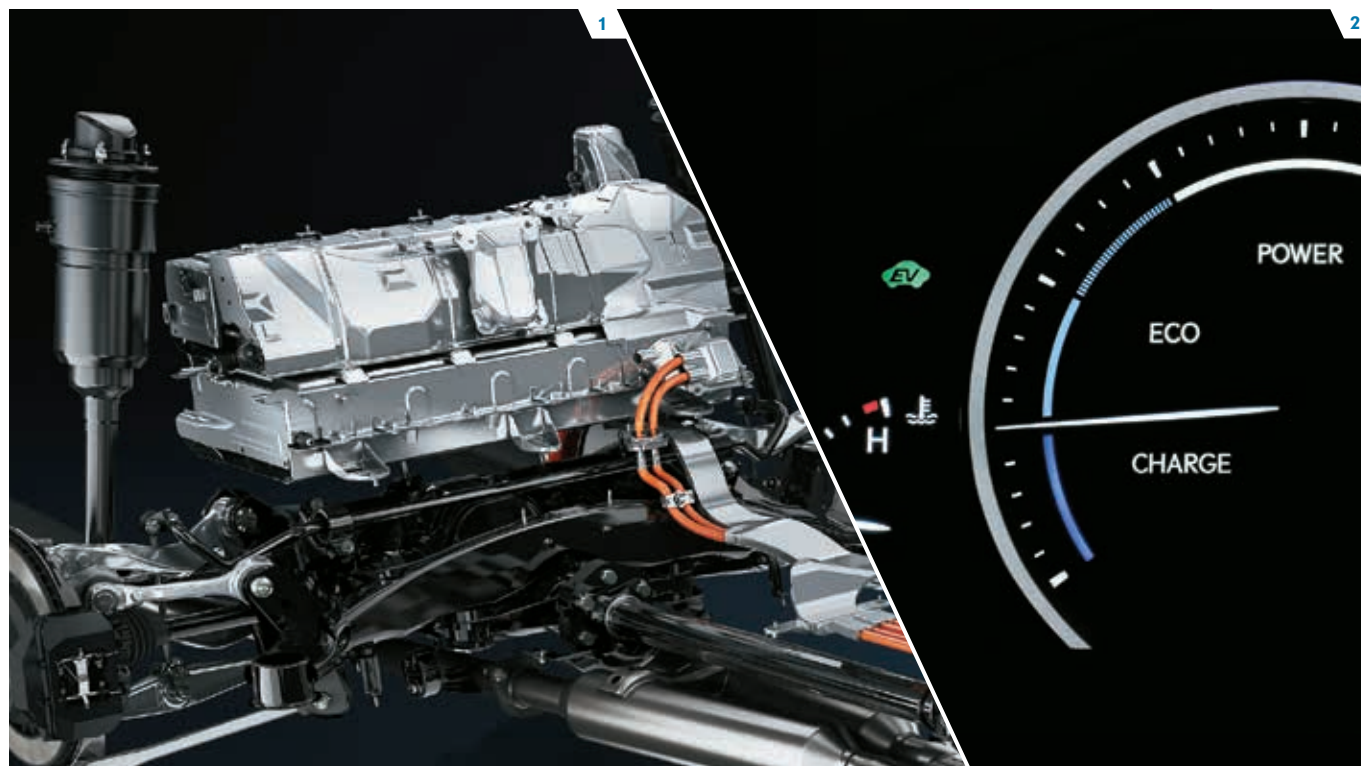

Comprising a 5.0-litre V8 petrol engine and 224 DIN hp electric motor, the LS 600h's Lexus Hybrid Drive delivers 445 DIN hp of refined power via permanent All-Wheel Drive. The brain of the system is a Power Control Unit (PCU) located under the bonnet, which controls the allocation of the car's power resources. At other times, it directs electricity to the advanced compact battery for later use.

1 / Hybrid battery The LS 600h's battery occupies minimum room.

The nickel-metal hydride battery provides high power output in relation to its weight. It does not require recharging from an outside power source, nor does it require periodic replacement.

2 / Electric Vehicle (EV) Mode With sufficient battery charge, EV mode lets you drive at lower speeds over shorter distances using just electric power. EV mode is whisper quiet, emissions free and consumes no fuel at all.

3 / Regenerative braking When braking or decelerating, the vehicle's wheels drive the high-output electric motor so that it functions as a generator. Kinetic energy is then captured and converted into electric power. This is stored in the hybrid battery for later use.



FULL HYBRID TECHNOLOGY



1 / Blu-Ray® player and 9-inch screen The Rear Seat Entertainment System in the LS 600h features a separate DVD player and a 9-inch screen for the 5.1 home theatre entertainment experience. The system features a Lexus first; a high contrast, HD Blu-ray® player.

2 / Digital entertainment Favourite DVDs can be watched – when the vehicle is stationary – on the central display screen in all LS models. An iPod® can be played through the vehicle's speakers.

3 / 12.3-inch LED multimedia display Driver and front passenger can interact with multiple display screens using Remote Touch.

4 / Mark Levinson® Sound Among the world's finest in-car entertainment systems, a 19-speaker Mark Levinson® Reference Surround system is standard across the range and allows passengers to enjoy perfect 7.1-channel audio.

5 / Voice recognition When driving, voice commands are a convenient and safe hands-free way for the driver to control various on-board systems, such as Lexus Premium Navigation or a Bluetooth® enabled mobile phone.

6 / Parking Assist Monitor Engage reverse and the view behind the car is relayed to the 12.3-inch display, the split-screen additionally shows a parking assist sensor graphic and guide lines.

AUDIO, COMMUNICATION AND INFORMATION



1 / Drive Mode Select Drive Mode Select allows you to choose between ECO, NORMAL, SPORT S and SPORT S+(with AVS) modes, for maximising the car's efficiency, dynamism or refinement. On Hybrid models Electric Vehicle (EV) mode is also available.

2 / Adaptive Variable Suspension Available on LS 460 F Sport enables fine-tune handling characteristics using Drive Mode Select, and the car even lowers itself for improved aerodynamics at higher speeds.

3 / Variable Gear Ratio Steering The LS is equipped with precise and speed-sensitive Variable Gear Ratio Steering (VGRS) that adjusts itself according to your speed and, in an emergency, will react to help you steer away from danger or out of a skid.

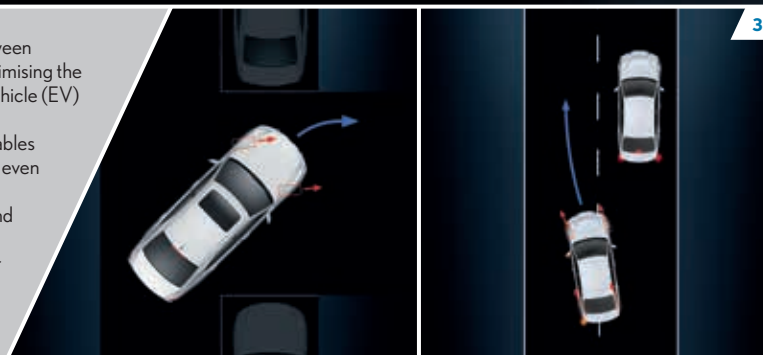

DYNAMIC PERFORMANCE



1 / Blind Spot Monitor and Rear Cross Traffic Alert Features on only the LS 600h. Blind Spot Monitor: radar devices detect vehicles in adjacent lanes that are not visible in the door mirrors. If the driver is indicating to change lane and a vehicle enters the blind spot, an illuminated warning signal appears on the door mirror (s). Rear Cross Traffic Alert (RCTA): when reversing, for instance in a busy car park, the Rear Cross Traffic Alert (RCTA) function uses the Blind Spot Monitor radar to detect vehicles approaching the difficult-to-see area behind the vehicle. When a vehicle is detected, the RCTA function alerts you with a visual display in the door mirrors and a buzzer.

2 / Driver Monitoring System The LS 600h utilises built-in digital cameras with near-infrared LEDs, the Driver Monitoring System can detect if your eyes are shut or if you've been distracted from the road ahead by sensing if your head is turned. Warnings are then activated as appropriate.

3 / Advanced Pre-Crash, Rear Pre-Crash Safety Advanced Pre-Crash Safety is the industry's most advanced safety system and can even detect errant pedestrians. Only available on the LS 600h, a computer uses radar, a camera and infrared projectors to constantly calculate collision risk, then warns the driver and reacts if necessary. If a rear collision seems likely, the front seat Pre-Crash Intelligent Headrests will move forwards and upwards, reducing the risk of whiplash injury.

4 / Lane Keeping Assist This innovative technology, available only on the LS 600h helps prevent you from inadvertently drifting out of lane, by way of a warning and the automatic application of a brief corrective steering force.

5 / Airbags The LS 460 is equipped with eight airbags and also features a breakthrough twin-chamber front passenger airbag. The LS 600h has three additional rear-seat airbags.

6 / Night View This optional feature on the LS 600h combines a powerful infrared camera with near-infrared light projectors, the Night View system captures an illuminated nocturnal image of the area in front of the vehicle. Shown within the 12.3-inch display, this helps reveal objects ahead well before they could be spotted by the naked eye.



ADVANCED SAFETY



1 / Adaptive High Beam System (AHS) Adaptive High Beam System standard only on the LS 600h uses a light-sensing camera to detect the headlights of oncoming vehicles and tail lights of those ahead, automatically shading part of the light beam with shutters so as not to dazzle drivers ahead.

2 / HID lighting High Intensity Discharge (HID) xenon headlights and an Intelligent-Adaptive Front-lighting System are standard on the LS 460. The lights are auto-levelling and have pop-up cleaners.

3 / Follow me home To light your path to and from the LS, the low-beam headlights and door mirror lights can be activated to remain on for 30 seconds, or longer if you wish using the customisation settings in the navigation system.

4 / Heated / folding door mirrors The heated door mirrors can be folded in electrically. Electrochromatic technology also dims the mirrors to prevent the risk of being dazzled by following traffic.

5 / 18" alloy wheels 10-spoke alloy wheels with 235/50 R18 tyres on LS 460 Luxury.

6 / 19" alloy wheels As fitted to LS 600h. With 245/45 R19 tyres.

7 / LED fog lights The LED fog lights on the LS 600h & LS 460 Luxury are the world's smallest in diameter and have a lens shape that combines beautifully with the spindle grille and LED daytime running lights.

8 / All LED lighting Available on the LS 600h only as the first Lexus model to introduce LEDs for all exterior lights. For the headlights, the development team further evolved the characteristic Lexus three-lamp design. Positioning the low beams higher than the high beams creates a dynamic look.

9 / LED rear lights and active brake lights The rear combination lights use elegant LEDs arranged in a Lexus 'L' form. Featuring aero-stabilising fins to reduce turbulence, when braking heavily, the lights pulse rapidly to warn following vehicles.



EXTERIOR FEATURES



1 / Climate Concierge / Nanoe® technology 'Climate Concierge', available only in the LS 600h continuously monitors and automatically adjusts cabin, seat and steering wheel temperatures. Additionally, infrared sensors track the body temperature of your rear seat passengers and adjust accordingly. Award-winning Nanoe® technology, standard across the range purifies the cabin air, effectively deodorises seats, and moisturises your skin and hair.

2 / Rear centre armrest The LS 600h's rear centre armrest features an LCD display to set the rear climate zone, control the audio and operate the rear blind.

3 / Electric Seat Adjustment The driver and front passenger seats have 10-way electric adjustment with memory.

4 / Rear massage seat Exclusively in the LS 600h a relaxation seat that reclines by up to 45 degrees, with extending thigh and footrest. The back seat incorporates eight air pockets that perform 'Shiatsu' acupressure massages.

5 / Dynamic LED interior illumination As you approach the car the door mirror lamps and clock light switch on to welcome you. When you unlock the doors, the daytime running lights illuminate. Pressing the START button then activates a champagne-coloured LED animation on the multimedia display and dashboard.

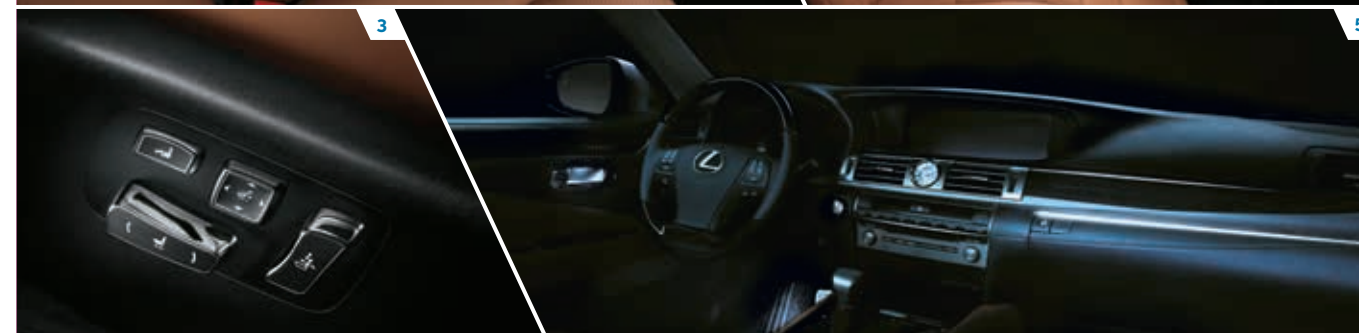
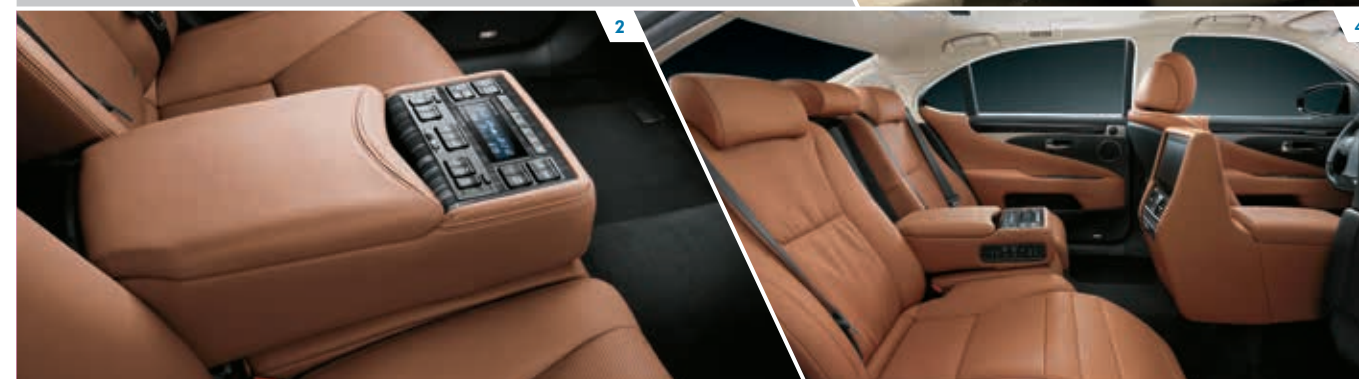

INTERIOR FEATURES



1 / Exclusive front bumper and grille A distinctive honeycomb spindle grille and unique bumper make the F SPORT instantly eye-catching. The deeper, lower section incorporates an integral spoiler and is complemented by two separate outer mesh grilles.

2 / F SPORT badge The discreet F SPORT logo is a badge of distinction. Its motorsport inspired design hints at its shared lineage with the Lexus LFA V10 supercar.

3 / BBS® 19" forged wheels Exclusive F SPORT design BBS® 19" forged aluminium wheels are fitted with low-profile tyres. Brembo® ventilated disc brakes ensure immense stopping power.

F SPORT EXTERIOR DESIGN

1 / F SPORT gearshift Finished in perforated leather, the F SPORT gearshift design matches the steering wheel to create a cohesive sense of sporting intent.

2 / F SPORT leather upholstery A new perforated leather design has been developed for the 10-way electrically adjustable F SPORT driver's seat. Embossed with the F SPORT emblem and featuring black or mellow white interior colours, all F SPORT interiors feature a black roof.

3 / Aluminium inlays The brushed aluminium inlays complement the drilled sport pedals, scuff plates and F SPORT interior trim elements.

4 / Drilled sport pedals The high-grip aluminium pedals are exceptionally responsive.

5 / F SPORT steering wheel The perforated leather steering wheel features the F SPORT logo, paddle shifters, and audio/phone controls with voice recognition.

6 / Aluminium scuff plates The inset front and rear door scuff plates, which illuminate in the dark, are finished in brushed aluminium and inscribed with the Lexus logo.



F SPORT INTERIOR DESIGN



	LS 600h	LS 460
MAXIMUM OUTPUT		
DIN hp / kW	445 / 327	387 / 285
ENGINE		
Capacity (cm ³) / Cylinders / Valves	4969 / V8 / 32	4608 / V8 / 32
Valve mechanism	DOHC with Dual VVT-iE	DOHC with Dual VVT-iE
Fuel type	Petrol, 95 octane or higher	Petrol, 95 octane or higher
Maximum output (DIN hp / kW @ rpm)	394 / 290 @ 6400	387 / 285 @ 6400
Maximum torque (Nm @ rpm)	520 @ 4000	493 @ 4100
HYBRID DRIVE		
Type	Synchronous, permanent magnet	
Max. output (DIN hp / kW)	224 / 165	
Max. torque (Nm)	300	
High voltage battery	Nickel-Metal Hybride (Ni-MH)	
- Number of battery cells / System voltage (V)	240/650	
TRANSMISSION		
Driven wheels	Permanent All-Wheel Drive	Rear-Wheel Drive
Transmission	Hybrid drive transmission, incorporating Electronic-Continuously Variable Transmission (E-CVT) with sequential shift mode and 2-stage motor speed reduction device	8-speed automatic with sequential shift mode
PERFORMANCE		
Maximum speed (mph)	155	155
0-62 mph (s)	6.3	5.7
EMISSIONS*		
Emissions level	Euro 6	Euro 6
Combined CO ₂ (g/km)	199	249
FUEL CONSUMPTION* mpg		
Combined	32.8 (8.6)	26.4 (10.7)

TECHNICAL DATA

	LS 600h	LS 460
BRAKES		
Front	Ventilated discs	Ventilated discs (Brembo)**
Rear	Ventilated discs	Ventilated discs (Brembo)**
SUSPENSION		
Front	Multi-link air suspension	Multi-link air suspension
Rear	Multi-link air suspension	Multi-link air suspension
STEERING		
Type	Rack and pinion with Electronic Power Steering & Variable Gear Ratio Steering	Rack and pinion with Electronic Power Steering & Variable Gear Ratio Steering
Minimum turning radius (m)	5.9 tyre 6.3 body	5.5 tyre 5.9 body** 5.4 tyre 5.8 body
WEIGHTS (kg)		
Gross vehicle weight	2815	2455
Kerb weight (min.-max.)	2370-2440	1940-2080 (1980-2020)**
DRAG COEFFICIENT		
Cd value	0.27	0.26
CAPACITIES (l)		
Fuel tank	84	84
Luggage compartment - with Spare Wheel		560
Luggage compartment - with tyre repair kit	420	

* All fuel consumption (mpg) and emissions (CO₂) figures quoted are sourced from official EU-regulated tests. These are provided for comparability purposes only and may not reflect your actual driving experience. Fuel consumption and emissions vary significantly depending on driving style, conditions, vehicle weight and speed. In order to allow consumers to compare and make informed choice between vehicles, there is a European Commission Standard (93/116/EC and 692/2008) to measure fuel consumption. For further information about the tests performed, please visit <http://www.dft.gov.uk/vca/fcb/faqs-fuel-consumption.asp> Please note: further Technical Data, including any updates, can be found at www.lexus.co.uk All figures quoted in relation to hybrid vehicles include both electric and petrol running cycles.

** F SPORT

Measurements in mm

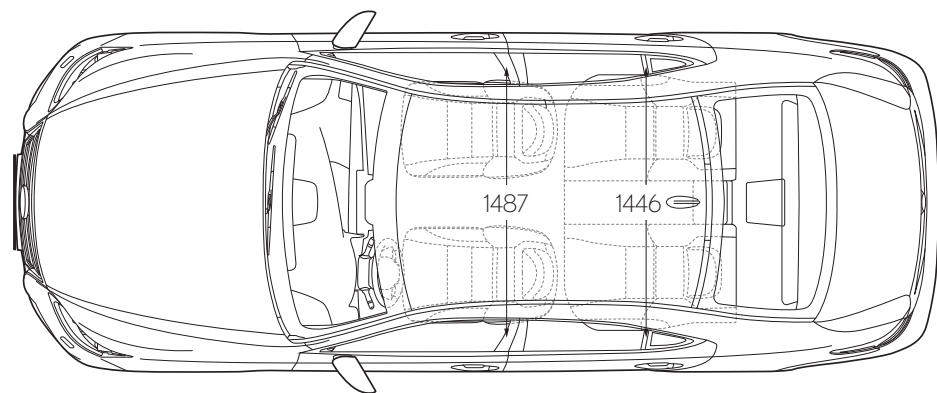
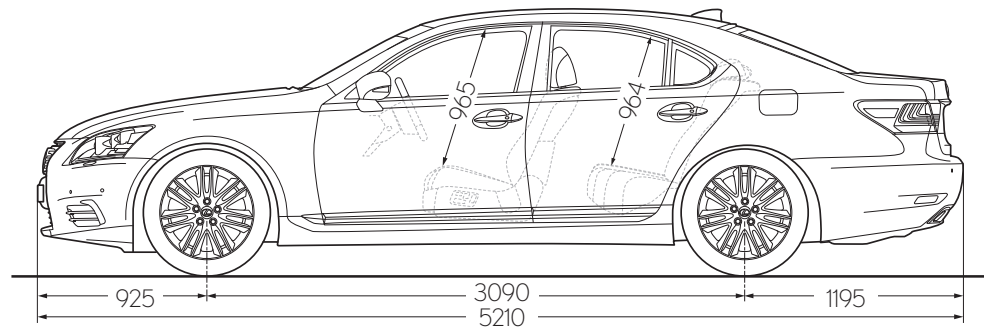
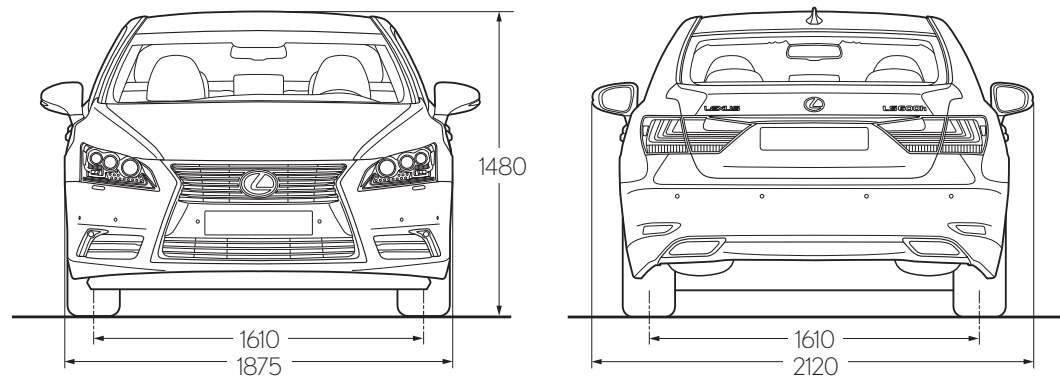

DIMENSIONS LS 600h

Measurements in mm

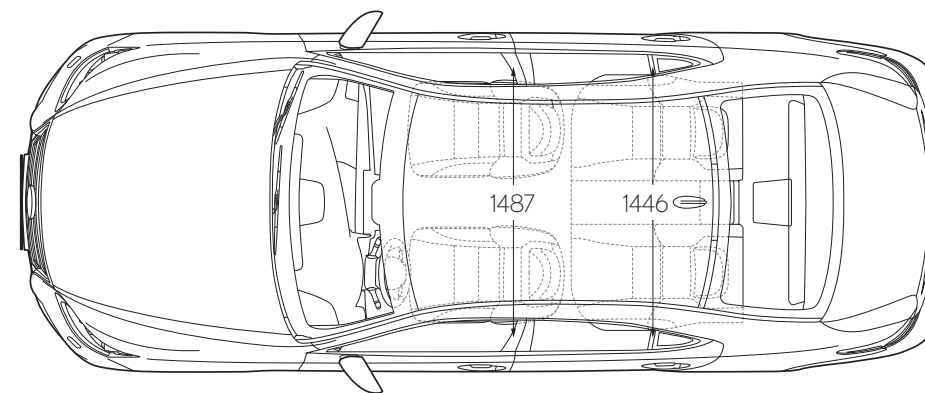
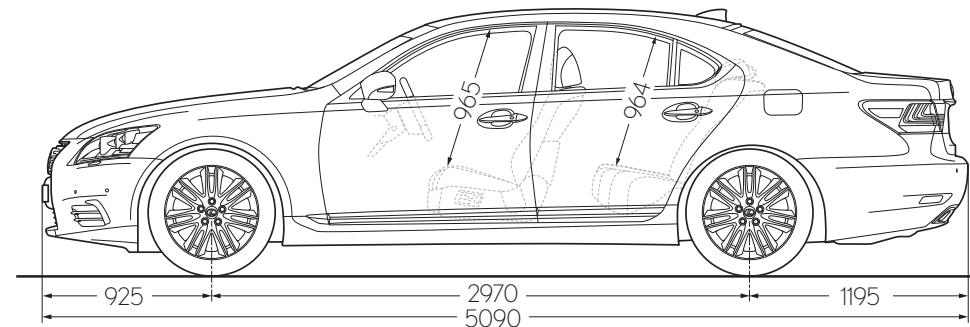
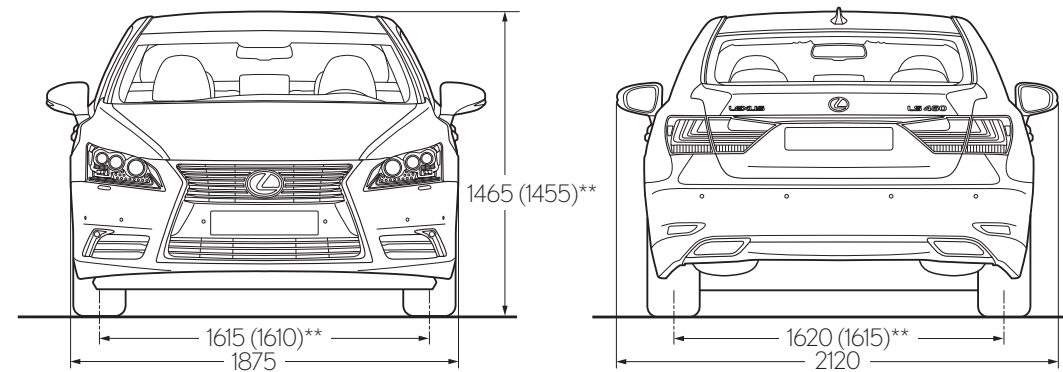

Headlights shown not available on LS 460
** F SPORT

DIMENSIONS LS 460

ACTIVE SAFETY AND DRIVING DYNAMICS

- ABS (Anti-lock Braking System)
- BAS (Brake Assist System)
- TRC (Traction Control)
- ECB (Electronically Controlled Braking)
- EBD (Electronic Brake force Distribution)
- VSC (Vehicle Stability Control) with cut off switch
- VDIM (Vehicle Dynamics Integrated Management)
- EPS + VGRS power steering (Electric Power Steering & Variable Gear Ratio Steering)

PASSIVE SAFETY

- Driver and front passenger 2-stage airbag
- Driver and front passenger knee airbag
- Driver and front passenger TAP (Thorax Abdomen Pelvis) extended side airbags
- Curtain shield airbags
- Front passenger airbag cut-off switch
- ISOFIX attachment (rear seats)
- Seatbelt pre-tensioners (front and rear)
- WIL (Whiplash Injury Lessening) front seats

EXTERIOR

- LED daytime running lights
- Headlight washers
- LED (Light Emitting Diode) rear lights
- Outside rear-view mirrors; electrically adjustable, heated, foldable, electrochromatic (auto-dimming) and illuminated
- Laminated front side windows with UV-reduction glass
- Rain-sensing wipers
- Parking assist sensors, front and rear

AUDIO, COMMUNICATION AND INFO

- 19-speaker Mark Levinson® premium surround system, FM/AM tuner, DVD player, RDS, Bluetooth®, USB and AUX connection
- Digital Audio Broadcasting (DAB) radio
- Full map navigation system
- Multi-information display in centre instrument cluster
- 12.3" Multimedia Screen

SECURITY

- Anti-theft system, alarm and immobiliser
- Auto door locking with double door lock
- Smart entry and start system

INTERIOR COMFORT AND CONVENIENCE

- Cruise control
- LED interior illumination
- Dynamic illuminated entry system
- Electrically adjustable steering column with auto-tilt and telescopic with memory
- Electronic climate control with separate Driver/Passenger temperature controls, clean air filter and Nanoe® ion generator
- Electrochromatic rear view mirror
- Total seating capacity = 5 seats

● Standard ○ Optional

18" alloy wheels 10-spoke (235/50 R18)

19" F SPORT Forged alloy wheels 10-spoke (245/45 R19)

19" alloy wheels 15-spoke (245/45 R19)

Space Saver Spare Wheel

Tyre Repair Kit

HID (High Intensity Discharge), bi-xenon headlights with I-AFS (Intelligent - Adaptive Front-lighting System)

LED headlights with AFS (Adaptive Front-lighting System) and AHB (Adaptive High Beam)

Leather upholstery with electrically adjustable heated and air conditioned front seats

High-grain leather upholstery with electrically adjustable heated and air conditioned front and rear seats

Alcantara lining on roof, pillars and sun visors

Electric front seat adjustment Driver 16-way and Passenger 10-way with memory

Left rear seat electrically adjustable with memory and lumbar massage

F SPORT leather steering wheel (3-spoke)

Wooden steering wheel (3-spoke) with heated leather pad

4-zone climate control with rear air conditioner and cooler

F SPORT interior and exterior styling package

F SPORT specific suspension tuning

Advanced pre-crash safety system

Rear passenger side airbags & rear seat cushion airbag (relaxation seat)

Adaptive cruise control with full speed following function

Lane keeping assist system

Blind spot monitor with rear cross traffic alert

Rear seat relaxation package with Ottoman seat

Front power active headrest - Driver: with memory, Passenger: electrically folding

9" VGA monitor and DVD player Rear display in console with DVD + Blu-ray®

Rear seat with footrest, electrically reclining

Night view monitor

Card key

Sunroof

	LS 460 LUXURY	LS 460 F SPORT	LS 600h PREMIER
18" alloy wheels 10-spoke (235/50 R18)	●		
19" F SPORT Forged alloy wheels 10-spoke (245/45 R19)		●	
19" alloy wheels 15-spoke (245/45 R19)			●
Space Saver Spare Wheel	●	●	
Tyre Repair Kit			●
HID (High Intensity Discharge), bi-xenon headlights with I-AFS (Intelligent - Adaptive Front-lighting System)	●	●	
LED headlights with AFS (Adaptive Front-lighting System) and AHB (Adaptive High Beam)			●
Leather upholstery with electrically adjustable heated and air conditioned front seats	●	●	
High-grain leather upholstery with electrically adjustable heated and air conditioned front and rear seats			●
Alcantara lining on roof, pillars and sun visors			●
Electric front seat adjustment Driver 16-way and Passenger 10-way with memory	●	●	●
Left rear seat electrically adjustable with memory and lumbar massage			●
F SPORT leather steering wheel (3-spoke)		●	
Wooden steering wheel (3-spoke) with heated leather pad	●		●
4-zone climate control with rear air conditioner and cooler			●
F SPORT interior and exterior styling package		●	
F SPORT specific suspension tuning		●	
Advanced pre-crash safety system			●
Rear passenger side airbags & rear seat cushion airbag (relaxation seat)			●
Adaptive cruise control with full speed following function			●
Lane keeping assist system			●
Blind spot monitor with rear cross traffic alert			●
Rear seat relaxation package with Ottoman seat			●
Front power active headrest - Driver: with memory, Passenger: electrically folding			●
9" VGA monitor and DVD player Rear display in console with DVD + Blu-ray®			●
Rear seat with footrest, electrically reclining			●
Night view monitor			○
Card key			●
Sunroof	○	○	●

STANDARD EQUIPMENT FOR ALL GRADES

ADDITIONAL EQUIPMENT BY GRADE

ROADSIDE ASSISTANCE

We want to ensure that you enjoy driving your Lexus anywhere in Europe with complete peace of mind. This is why we provide you with Lexus Roadside Assistance 24 hours a day, 365 days a year in both the UK and Europe*. Your membership gives you personal cover. That means you are entitled to the full range of benefits and services as the driver or passenger of any vehicle, not just while driving your Lexus. Your partner is also eligible for the same cover provided you both reside at the same address.

To make use of this added bonus, please register your partner with Lexus Roadside Assistance on 0800 169 0393.

*Lexus Roadside Assistance is provided for the first three years of owning the car.

THREE-YEAR COMPREHENSIVE WARRANTY

Any defect that is attributable to a manufacturing or assembly defect under normal use is covered by your warranty. This provision applies for a period of three years or 60,000 miles, whichever comes first, with no mileage limit for the first year. In the event of a breakdown immobilising your Lexus, the cost of recovering it to the nearest Lexus Centre is also covered if that breakdown is the result of a warrantable defect.

FIVE-YEAR HYBRID COMPONENT WARRANTY

For hybrid models, certain components within the hybrid drivetrain system have a five-year or 60,000 miles warranty, whichever comes first.

THREE-YEAR SURFACE RUST AND PAINTWORK WARRANTY

The three-year, unlimited mileage warranty covers surface rust and paint defects on any painted body panels due to a fault in material or workmanship.

12-YEAR CORROSION PERFORMANCE WARRANTY

A 12-year unlimited mileage warranty covers the vehicle against rust perforation through any sheet metal body panel (subject to certain exclusions specified in the warranty booklet) occurring as a result of a manufacturing or assembly defect in the vehicle. The warranty booklet supplied with each new vehicle gives full details. This warranty is also transferable to subsequent owners.

OWNING A LEXUS**ACCESSORIES**

Please consult your local Lexus Centre for the full specification of approved Lexus Accessory products.

LEXUSCARE®

For us, caring for your Lexus is the equivalent of caring for you, our customer. Each member of the Lexus team has honed their skills and knowledge to ensure that you experience the highest levels of care. This extends to every aspect of our service. Wherever possible we will provide a replacement car while yours is being maintained and we aim to ensure that any time you spend with us in the Lexus Lounge is relaxing and enjoyable. Read a paper, watch television or even work on your laptop. Excellence of service is more than just a goal, it's our passion. And, through the LexusCare® programme, that passion endures long after your car has left the showroom.

LEXUS FINANCIAL SERVICES

Lexus Financial Services offers an extensive range of finance products, including Lexus Connect - Contract Purchase and Lexus Connect - Contract Hire, products that offer a combination of benefits designed to make acquiring a Lexus as easy as driving one. Whether you are a private motorist looking for the most flexible, affordable options or a business wishing to boost cash flow and tax efficiency, our finance products provide attractive, refined solutions. Your Lexus Centre will be happy to discuss the full range of financing options available and create a quotation that is right for you. When you choose to go ahead your Lexus Centre will arrange your application. There are no lengthy forms to fill in and immediate acceptance is possible in many cases. Delivering complete customer satisfaction underpins everything we do at Lexus, so once you commence an agreement with us, you can rest assured that our team of UK-based customer service representatives are only a phone call away if you have any queries. Finance subject to status to over-18s. Terms and conditions apply. Indemnities may be required.

WORLD-LEADING QUALITY

Since its launch, Lexus has been in the vanguard of what is achievable in the luxury automobile category. Our long list of awards and quality records is proof of this achievement: in addition to awards for best luxury car, best chauffeur car, best security and being rated best manufacturer, over the past decade Lexus has continued to lead the way in customer satisfaction and has been awarded the highest position in several UK vehicle ownership satisfaction studies.





LS 460 LUXURY:

Leather **1** / Ivory **Inlay A** / Dark Brown Walnut Wood
 Leather **2** / Mellow White **Inlay B** / Brown Ash Burl Wood
 Leather **3** / Light Grey **4** / Black **5** / Topaz Brown
Inlay C / Black & Grey Shimamoku

LS 460 F SPORT:

Leather **6** / Mellow White **7** / Black **Inlay D** / Aluminium

LS 600H PREMIER:

Semi-aniline leather **8** / Ivory **Inlay A** / Dark Brown Walnut Wood
 Semi-aniline leather **9** / Mellow White **Inlay B** / Brown Ash Burl Wood
 Semi-aniline leather **10** / Light Grey **11** / Black
12 / Topaz Brown **Inlay C** / Black & Grey Shimamoku

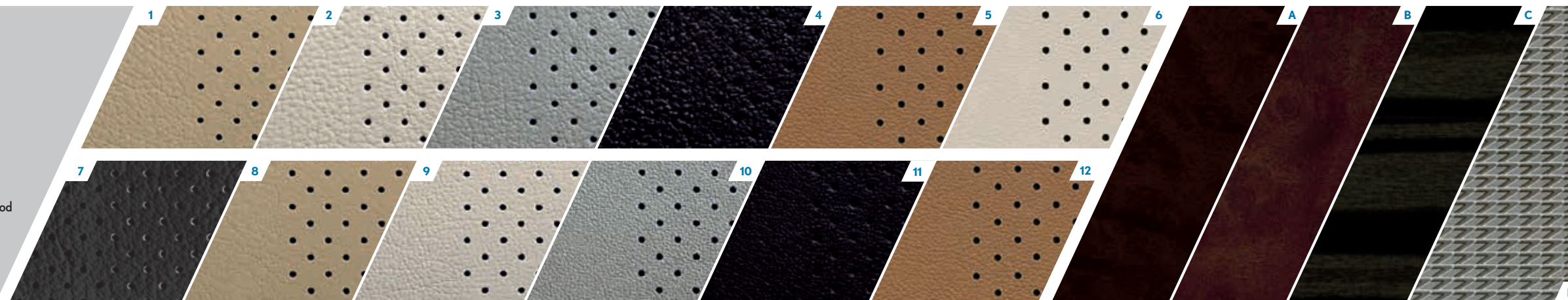

INTERIOR COLOURS





VELVET BLACK (212)³



OBSIDIAN BLACK (214)²



CELESTIAL BLACK (217)



MERCURY GREY (1H9)



MESA RED (3R1)



SONIC TITANIUM (1J7)



SONIC SILVER (1J2)



ARCTIC PEARL (077)²



F SPORT WHITE (083)¹

EXTERIOR COLOURS

¹ Exclusive to F SPORT models ² Not available on F SPORT models ³ Solid colour



EXPERIENCE THE LEXUS LS

INFORMATION CONTAINED IN THIS BROCHURE

Accuracy and Specification

All information contained in this brochure was correct at time of going to print. Please note that while every effort is made to reproduce accurate information, we reserve the right to change specifications, equipment and availability without prior notice. Images shown in this brochure may not be of UK models (for example, they may show left hand drive vehicles) and may illustrate equipment that is only available on selected grades. Therefore, this brochure cannot be regarded as infallible and, as such, does not constitute an offer for sale of any particular vehicle shown.

Fuel consumption & emissions data

All mpg, mph and CO₂ figures quoted in this brochure are sourced from official EU-regulated test results. These are provided for comparability purposes only and may not reflect your actual driving experience. Fuel consumption and emissions vary considerably depending upon driving style, conditions, vehicle load and speed. All figures quoted in relation to hybrid vehicles include both electric and petrol running cycles.

In order to allow consumers to compare and make an informed choice between one vehicle and another, there is a European Commission standard (93/116/EC and 692/2008) to measure fuel consumption. This common standard must be adhered to by all manufacturers selling motor vehicles in the EU and is the basis for all published fuel consumption figures. For information on how fuel consumption tests are performed please visit: <http://www.dft.gov.uk/vca/fcb/faqs-fuel-consumption.asp>.

Safe driving

Lexus is committed to promoting safe and responsible driving at all times. None of the images contained in this brochure should be taken to promote any unsafe driving practice. All sound, entertainment and navigation accessories that may be included in our vehicles should always be used alongside legal and attentive driving. Additionally, any driver assistance and other safety features included in our vehicles are not designed to substitute safe and careful driving.

End-of-life vehicles

Taking care of the environment is a priority for Lexus. We strive to minimise the environmental impact of our vehicles throughout their life cycle – from design, production, distribution, sales and service to end-of-life. For more detailed information on environmental performance please visit www.lexus.co.uk.

Arranging a test drive

We hope to have illustrated in this brochure that Lexus creates vehicles of refinement, innovation and style. But only behind the wheel of one of our models can you truly experience the pleasure, performance and seamless anticipation of your needs as a driver at first hand. Simply consult your local Lexus Centre to arrange a test drive.

Further information & contact us

For further information, to find out more about owning a Lexus or simply to locate your local Lexus Centre, please visit our website, www.lexus.co.uk, or call 0845 278 8888.

About Lexus

Lexus is a division of Toyota (GB) PLC. Toyota (GB) PLC is a company registered in England & Wales with company number 0916634 and with its registered office at Great Burgh, Burgh Heath, Epsom, Surrey KT18 5UX.

Toyota (GB) PLC is an introducer appointed representative of Toyota Insurance Management Limited and Toyota Financial Services (UK) PLC, both of which are authorised and regulated by the Financial Conduct Authority. Toyota (GB) PLC is a member of the Society of Motor Manufacturers & Traders.



GBNGL-LS115-VB
January 2015

View Offers



Watch the Advert



Find a Dealer



Book a Test Drive

